

Article number: 201605151

Description: Lock nut ISO 8675 B-M20x1,5 Stainless

Measures

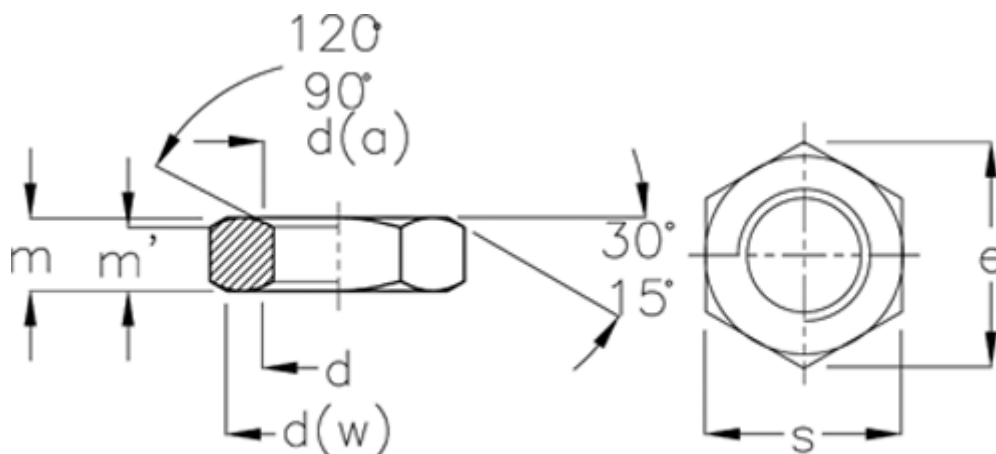

d	= M20	m min	= 9.10
d1 max	= 21.6	s max	= 30
d1 min	= 20	s min	= 29.16
d2	= M20	Thread pitch	= 1.5
d3	= 1.5	w	= 27.70
e	= 32.95		
m	= 7.28		
m max	= 10		